

# Magnetic Lifting & Handling Systems

Safe & efficient handling for manufacturing and assembly lines.

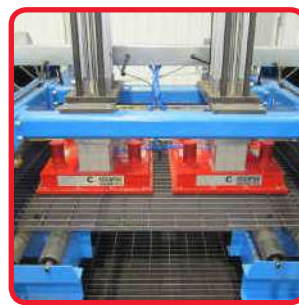

The safest, most efficient way to move ferrous loads



# Eclipse Magnetics

100 years of manufacturing excellence



Serving some of the leading names in industry

**JCB**

**Caterpillar**

**Corus**

**TATA Steels**

**NSK**

**BMW**

**Ford**

**Perkins**

**Fanuc**

**ABB Robotics**

**Yaskawa**

## A world leader in magnetic technology

With 100 years of experience in the design and manufacture of high performance magnetic systems, we supply critical equipment to some of the leading names in the most demanding industries. Our magnetic technology is widely used in major development projects worldwide, all requiring a guarantee of premium performance.

## Designing excellence

We have a track record of producing high quality products backed by a commitment to total customer service. Our technical application teams have a wealth of experience, ensuring that many of our products are market leading innovations. All manufacturing is carried out using ISO 9001 certified quality management systems and we are ISO 14001 accredited. We are also fully conversant with specific industry certifications.

## Unrivalled product range

We serve worldwide markets with extensive magnetic product ranges including:- handling systems, magnetic filtration, foreign body removal systems, magnet assemblies and complex magnetic industrial equipment used in industries such as automotive, aerospace and nuclear. Many of our products are unique and covered by global patents.

## Worldwide support

We offer worldwide support through our offices in the UK, Canada and China. We also have numerous employees in various territories and a network of technically trained partners to provide local product support.



# Improve your process efficiency

Ultimate speed & efficiency combined with total safety

Eclipse Magnetics' lifting and handling systems are based on fail-safe magnetic technology which delivers world class results. Ideal for applications ranging from light pick and place equipment to heavy steel stock movement, magnetic lifting is the most efficient solution for handling ferrous loads.

In comparison to other methods such as slings, chains, hooks and grabs, magnetic systems present major benefits to manufacturing, assembly and storage sites:-



**Simple, easy use**  
ready to use in minutes,  
simple, safe operation.



**Increased number of lifts per hour**  
simple on-off operation,  
engages the load in seconds.



**Total safety....**  
incorporates numerous  
fail safe mechanisms.



**Precision lifting**  
magnetic lifting systems  
provide a greater lift control.



**Single person or automated use**  
complete safety, minimal  
training, labour efficient.



**Zero running costs**  
permanent magnetic  
technology does not require a  
sustained power source.



**Optimises storage space**  
floor space optimised as  
access only required to one  
lifting face.



**No load damage**  
protects the product finish,  
ideal for painted or coated  
surfaces.



## Total Safety – the safest way to lift ferrous loads

Operation safety is the foremost consideration in the design of all our magnetic lifting and handling systems. Permanent magnetic technology with built in fail-safe mechanisms and a 3:1 lift safety factor (Battery lifter 3:1) ensures complete safety for all operations.

All our products comply with HSE regulations and guidelines such as the Lifting Operations and Lifting Equipment Regulations 1998 (LOLER) and the Provision and Use of Work Equipment Regulations 1998 (PUWER) (UK Regulations).

Our permanent lifters are also designed in accordance with ASME BS30.20-2010.



# Magnetic lifting and handling

Optimising process efficiency in diverse applications

## Raw materials



**Our lifting and handling systems are widely used for handling raw materials in primary production stages, such as:-**

- Steel stockholders
- Steel production
- Steel fabrication shops
- Forgings and castings
- Tin products
- Coil handling
- Slab and plate transfer
- Profile picking

## Manufacturing



**Maximum efficiency combined with total safety are key requirements for demanding manufacturing applications. Our products are widely used in:-**

- Yellow goods manufacture
- Feed conveyors
- Digger blades
- Assembly lines
- Machine shops
- Mould making
- Bearing manufacture
- Canned food lines
- Paint cans
- Jar handling systems
- Tin can manufacture
- Turbo manufacture
- Springs
- Brake manufacture
- Engine block manufacture

## Automation



**Speed and precision accuracy, for single or multi-part loads, are key reasons why our systems are widely used in automation applications such as:-**

- Transfer lines
- Conveyor lines
- Pick and place equipment
- General engineering
- Robotics
- Packaging machinery
- Palletising/depalletising systems

# Give your business the edge.....

A few of our many satisfied customers...



## **Tyzak** **Machine Blades**

### **Product: Lifting Magnet**

The company manufacture shearing machine blades from raw black steel stock, the finished product is heat treated and has a ground finish.

Using traditional lifting systems, such as chains and slings, the size and profile of the parts were difficult to handle without marking the surface and edges of the load.

Eclipse Ultralift LM was specified to use at each stage of the process. This has resulted in faster more efficient lifting and now minimal damage occurs to the load during lifting.



## **JCB** **Construction Equipment**

### **Products: Electronically Switched Permanent Magnet (ESPM)**

This world renowned construction equipment OEM use ESPMs in many areas of production for clamping and transferring parts.

The ESPMs are used in process stages such as robotic pick and place of hydraulic cylinders and rams. They are used to feed and unload equipment during the manufacturing process. In addition they are used as a means of holding digger arms prior to tag welding.

Simple, fast loading and single surface contact have made a significant contribution to process efficiency.



## **FG Wilson** **Generator Manufacture**

### **Products: Pneumatically Switched Permanent Magnet (PSPM)**

This company manufacture large gas and diesel generators. Optimag P's were specified for lifting steel sheet which is used in the manufacture of enclosures for the generators.

The Optimags are mounted on a lifting frame. Optimag was the ideal solution for lifting single sheets of 3mm steel. With single face contact and instant clamping to the load, the Optimags improved lifting speeds and efficiency.



## **Leyland DAF** **Automotive**

### **Products: Customised Magnetic Lifter**

Leyland DAF move thousands of truck components each week around their production and assembly site. It is vital that they have the most efficient, trouble free lifting systems.

Moving leaf springs into position to mount onto axle sub-assemblies was previously a manual process which involved several operatives. Introducing an Optimag P increased speed of the lift and reduced the operation to a single person task.

The spring manufacturer subsequently adopted the same method on their manufacturing line.

# Optimum Lifting & Handling Solutions

Important considerations when choosing your product

## Permanent Lifters



Manually Switchable Permanent Magnet

## Optimag E



Electronically Switchable Permanent Magnet (ESPM)

## Optimag P

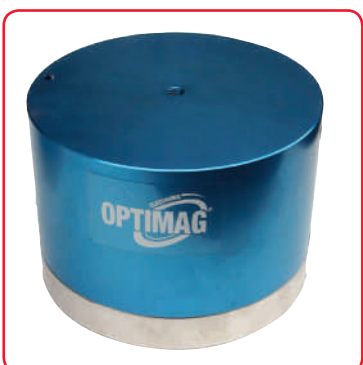

Pneumatically Switchable Permanent Magnet (PSPM)

## Product Selector

A guide on how to use our standard products. Please speak to our sales

Product Type	Page	Material shape		Recommended material thickness mm						Bright
		Flat	Round	1-4	5-8	8-12	12-20	20+	50+	
UL+ Lifters	9	✓	✓					✓		✓
LM Lifters	11	✓	✓					✓		✓
TP Lifters	12	✓			✓	✓	✓	✓		✓
90 Degree Lifter	15	✓					✓	✓		✓
Battery Lifters	16	✓	✓					✓	✓	✓
Optimag E	17	✓	✓			✓	✓	✓		✓
Optimag P	18	✓		✓	✓	✓	✓	✓		✓

Note: Table is an approximate guide, for specific applications please contact us.

## Important factors to consider

### Material Type

The scale opposite highlights the effect material type has on clamping forces.

### Workpiece Material

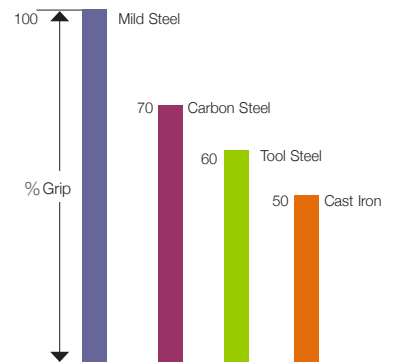

### Material Thickness

To achieve maximum clamping force minimum material thickness should be observed.

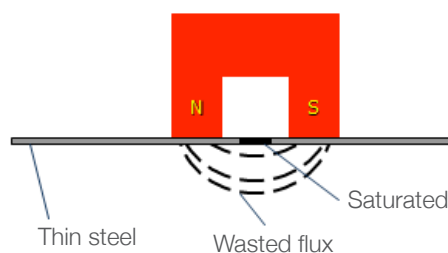

Minimum part thickness provides 100% performance

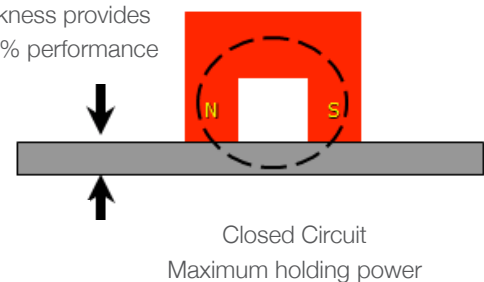





department for more information.

	Surface finish		Actuation method		
	Black	Scaled	Manual	Electronically	Pneumatically
	✓	✓	✓		
	✓	✓	✓		
	✓	✓	✓		
	✓		✓		
	✓	✓		✓	
				✓	
					✓

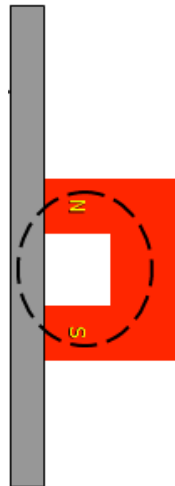

**Please Note:-** All specifications shown are based on a straight vertical lift. Should the load be rotated through 90° the safe working load will be reduced by 80% of the stated values.

## Air Gaps

An air gap between the magnet and the load will also affect lifter performance. The chart below shows the general effect on different materials.

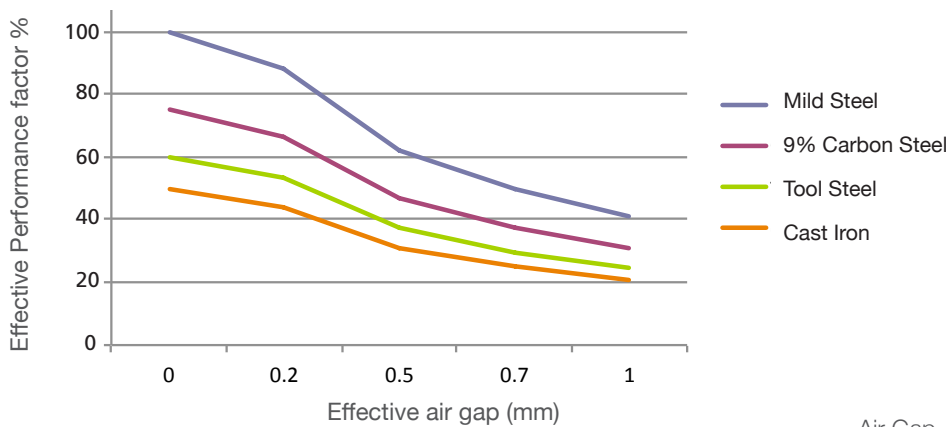

As the air gap increases the magnetic performance reduces.

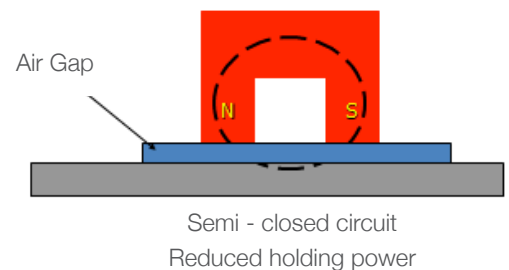

**Please note** information on these pages is an approximate guide, for specific applications please contact us.

# Ultralift<sup>PLUS</sup>

Premier Range

**3 YEAR  
WARRANTY**

The safest lift in the world

- The premier manually switchable magnetic lifter
- Provides fast and efficient lifting
- A range of built in safety features
- Guaranteed 3:1 safety factor

### Secondary Safety

**Safety button** - A safety catch locks the handle in the “on” position. This prevents any accidental release of the load once engaged.

**Handle** - After releasing the safety mechanisms, the magnet can be released easily, by using one hand.

**Space Saving** - Access only required to the load's top face allowing more efficient use of storage and handling areas.

### Primary Safety

**Lifting Eye** – once the lifting eye is under tension with the load a patented mechanism locks the handle ensuring that the raised load cannot be released either deliberately or accidentally.

### Primary Safety

**Safety Shim** – Ultralift Plus is the only permanent magnetic lifter to be supplied with a “safety shim” (internationally patented). This allows pre-testing of the load, irrespective of weight, material type, material thickness and surface condition. If it can be lifted with the safety shim in place, a 3:1 safety factor is guaranteed. This is ideal where the load, weight and size may vary.



## Technical Data

Product	Self Weight kg	Flat Section			Round Section			Dimensions mm							
		SWL * kg	Thickness Min. mm	Length Max. mm	SWL kg	Diameter Max. mm	Length** Max mm	A	B	C	D	E	F	G	H
UL0125+	4	125	20	1500	50	200	1500	101	155	69	74	64	152	34	27
UL0250+	11	250	25	1500	100	300	1500	155	214	92	96	96	218	51	40
UL0500+	27	500	30	2000	200	400	2000	224	300	122	128	124	266	63	49
UL1000+	63	1000	45	3000	400	450	3000	260	359	176	174	140	382	71	55
UL2000+	157	2000	55	3000	800	600	3000	368	477	233	227	195	552	102	79

\*Safe working load

⚠️\*\*Do not operate at maximum length and maximum diameter on the same item. ALWAYS work within SWL stated.



**No Running Costs** - No power required - no additional costs.

**High performance** - "Rare Earth" magnet material provides high performance.



### How it works

Manually rotating the handle changes the direction of the magnetic flux, thereby switching from on to off.

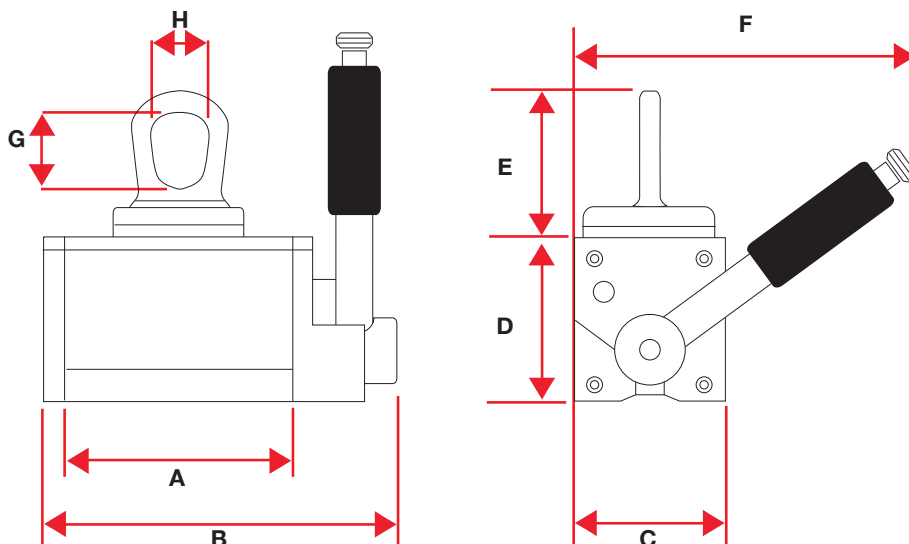
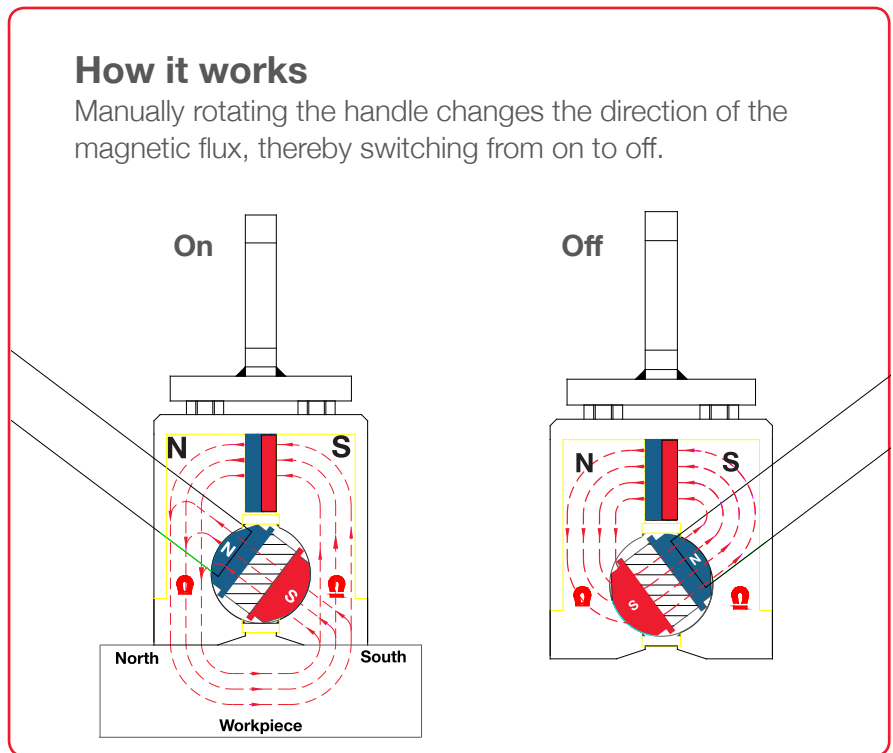



# Ultralift LM Economy Range

Safe, efficient, general purpose permanent magnetic lifter

- Standard manually switchable permanent magnetic lifter option
- Provides fast and efficient lifting
- Safety locking mechanism prevents accidental release of load



## Technical Data

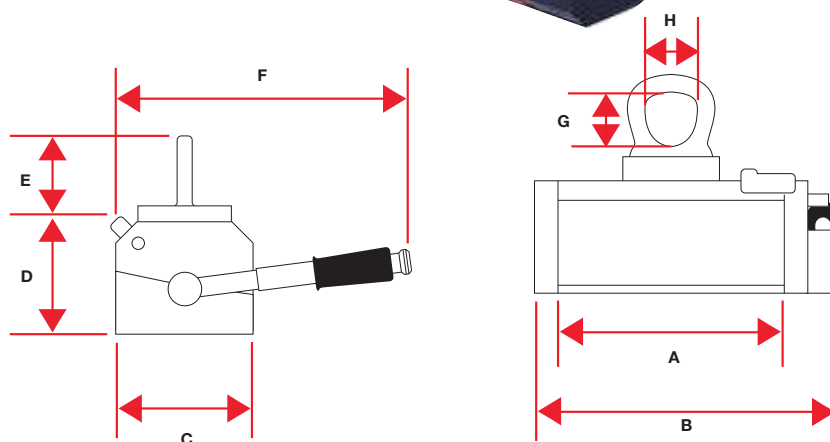

Product	Unit Weight kg	SWL* kg	Flat Section		Round Section			Dimensions mm							
			Thickness Min. mm	Length Max. mm	SWL* kg	Diameter Max. mm	Length** Max. mm	A	B	C	D	E	F	G	H
LM0125	4.5	125	20	1500	50	250	1500	110	146	76	62	54	150	30	27
LM0250	8.5	250	25	1500	100	300	1500	165	205	90	72	78	200	45	40
LM0500	17.5	500	30	2000	200	400	2000	225	275	106	88	103	243	53	48
LM1000	36.5	1000	45	3000	400	450	3000	325	383	136	103	113	365	59	52
LM2000	79	2000	55	3000	800	600	3000	400	470	186	132	170	526	88	79

\*Safe working load

△ \*\* Do not operate at maximum length and maximum diameter on the same item. ALWAYS work within SWL stated.

# Ultralift TP

The thin plate specialist

- Permanent magnetic lifter for the safe lifting of thin plate and pressings.
- Guaranteed lifting of single plates
- Simple, quick operation



## How it works

Manually rotating the handle changes the direction of the magnetic flux, thereby switching from on to off.

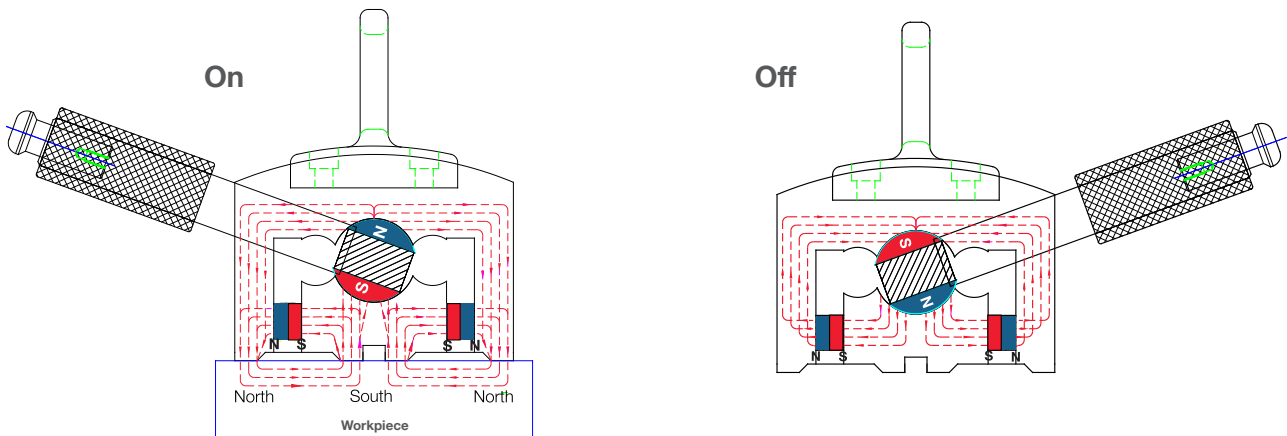

## Technical Data

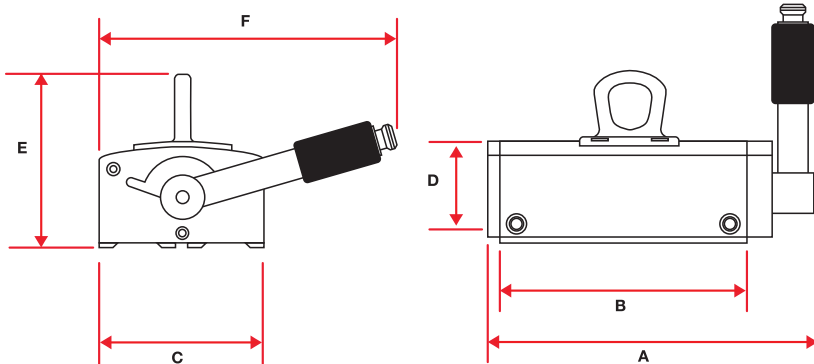

Product	Self Weight kg	Material Thickness								Dimensions mm					
		5mm		6mm		8mm		10mm		A	B	C	D	E	F
		SWL* kg	Length Max. mm	SWL* kg	Length Max. mm	SWL* kg	Length Max. mm	SWL* kg	Length Max. mm						
TP150	8	75	1500	100	1500	150	1500	200	1500	202	150	100	74	126	181
TP300	15	150	2000	200	2000	300	2000	400	2000	352	300	100	74	126	181

\*Safe working load

# Choosing a Manually Switchable Permanent Magnetic lifter

The tables below are a guide to determine a typical safe working load and load dimensions for each lifter option. Recommended use shown in WHITE.

\*\*\*\*RED shows typical reduction in load due to thickness of material. X- Cannot be used for stated dimensions.\*\*\*\*

\* Based on mild steel and bright finish.

## Flat parts

Product	SWL* Flat kg	Max Length (X) mm		Material Thickness (T) mm									
				10	15	20	25	30	45	60	70	80	100

### Ultralift Plus

UL0125+	125	1500	Max width (Y) (At material thicknesses shown).	480	500	527	422	352	234	176	151	132	105
UL0250+	250	1500		X	791	820	844	703	469	352	301	264	211
UL0500+	500	2000		X	X	947	997	1055	703	527	955	794	600
UL1000+	1000	3000		X	X	X	910	1406	938	703	603	527	422
UL2000+	2000	3000		X	X	X	X	700	1290	1750	1206	1055	844

### Ultralift LM

LM0125	125	1500	Max width (Y) (At material thicknesses shown).	480	500	527	422	352	234	176	151	132	105
LM0250	250	1500		X	791	820	844	703	469	352	301	264	211
LM0500	500	2000		X	X	947	997	1055	703	527	955	794	600
LM1000	1000	3000		X	X	X	910	1406	938	703	603	527	422
LM2000	2000	3000		X	X	X	X	700	1290	1750	1206	1055	844

Product	SWL* Flat kg	Max Length (X) mm		Material Thickness (T) mm							
				5	6	7	8	9	10	15	20

### Ultralift TP

TP150	200	1500	Max width (Y) (At material thicknesses shown).	1300	1440	1500	1500	1500	1500	1150	860	680
TP300	400	2000		2000	2000	2000	2000	2000	2000	1720	1290	1030

## Round parts

Product	SWL Round* kg		Diameter (D) mm						
			50	100	200	300	400	450	500

### Ultralift Plus

UL0125+	50	Max length (X) (At material thicknesses shown).	1600	820	200	X	X	X	X	X
UL0250+	100		3500	1640	400	180	X	X	X	X
UL0500+	200		3500	3280	800	360	210	X	X	X
UL1000+	400		X	4000	1600	720	420	308	X	X
UL2000+	800		X	X	3200	1480	840	616	370	X

### Ultralift LM

LM0125	50	Max length (X) (At material thicknesses shown).	1600	820	200	X	X	X	X	X
LM0250	100		3500	1640	400	180	X	X	X	X
LM0500	200		3500	3280	800	360	210	X	X	X
LM1000	400		X	4000	1600	720	420	308	X	X
LM2000	800		X	X	3200	1480	840	616	370	X

This chart is to assist but once material thickness is identified maximum length can be shorter and width can be greater providing total area remains the same per magnet. Once length / width (total area) exceeds the recommended dimensions for the thickness, additional magnets should be used. (See over page). Number of magnets will continue to increase pro rata to plate size. Always position magnets to suit thickest material. Contact our sales department for more information or for any specific requirements.



# Do's and Don'ts

## Positioning the lifter

### Component wider than the length of the magnet

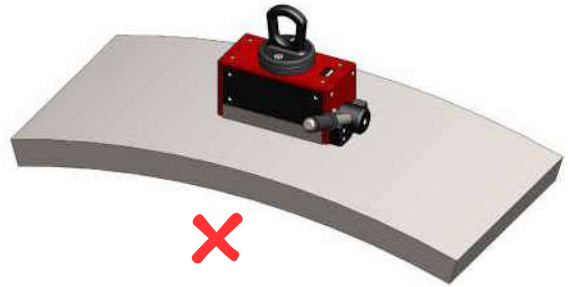
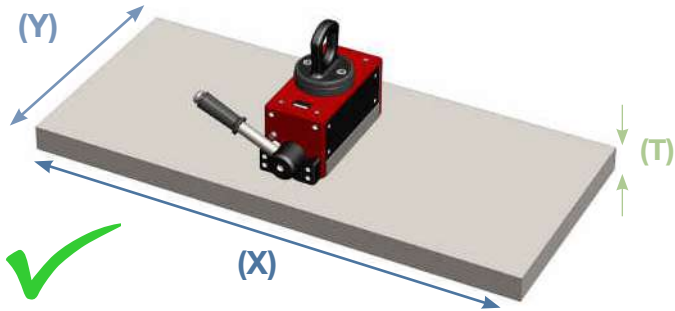

Magnet across increases clamping at possible point of peel.

### Component width less than the magnet length

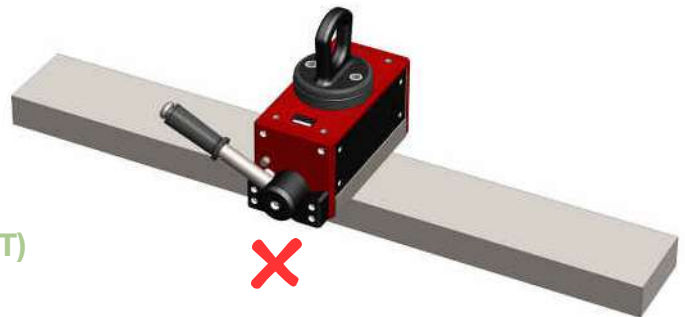
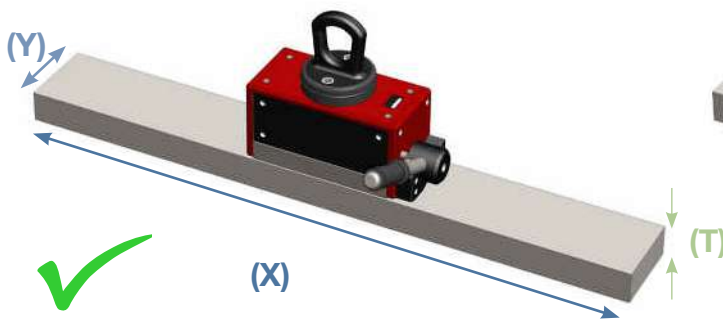

### Parts longer than maximum recommended length

Once Max length or Max SWL is reached multiple magnets must be used. Ideal positioning shown. **(Fig 1)**

Contact our sales department for specific requirements.

Lifting beams are available on request, please speak to our sales team for more information.

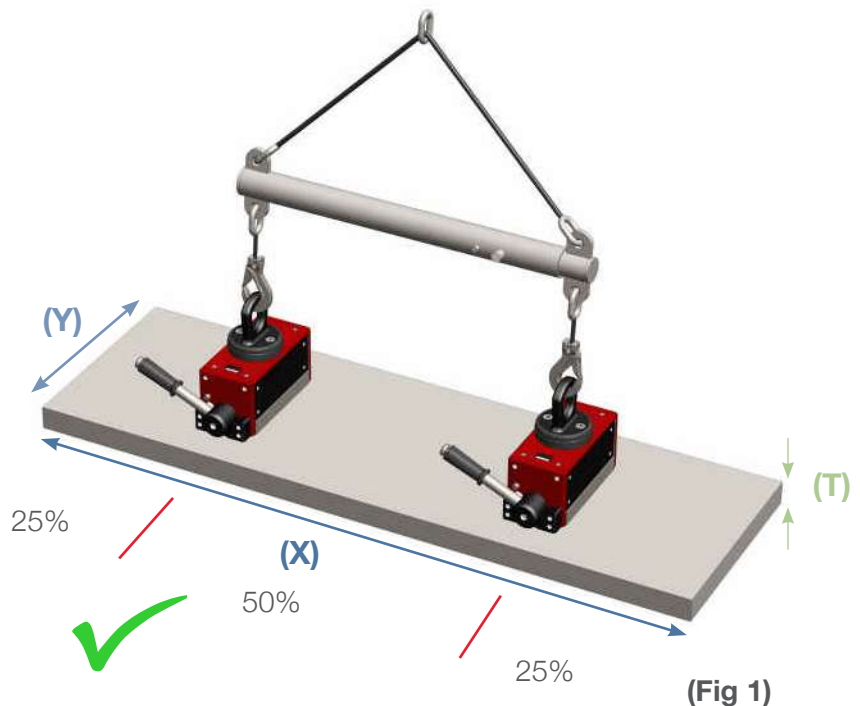

# 90° Disc and Plate Lifter

- Cost effective lifting frame with permanent lifting magnet.
- Ideal for lifting and rotating steel discs and plates in positioning and machine loading applications.
- Full adjustment and built in safety features.

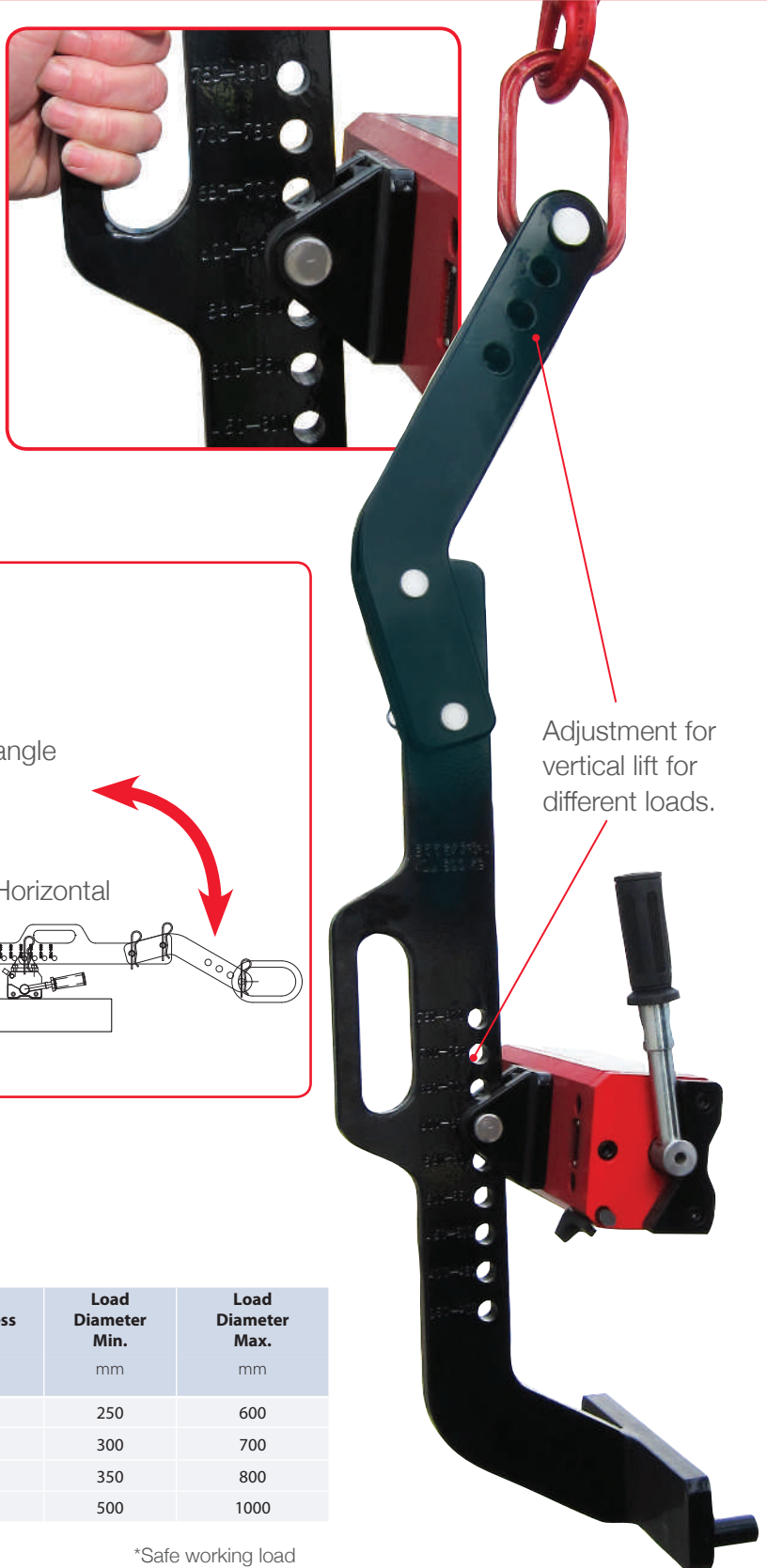

## How it works

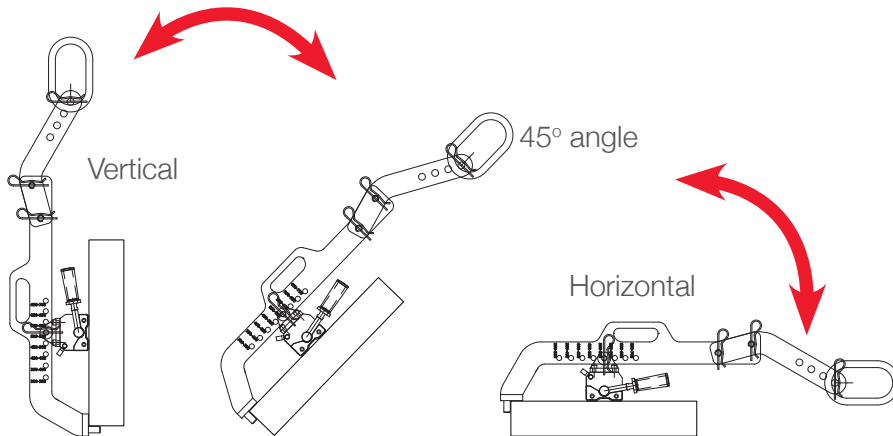

## Technical Data

Product	SWL* kg	Load Thickness Min. mm	Load Thickness Max. mm	Load Diameter Min. mm	Load Diameter Max. mm
LF125	125	20	55	250	600
LF250	250	30	80	300	700
LF500	500	40	125	350	800
LF1000	1000	50	160	500	1000

\*Safe working load

90° lifter can lift round and rectangular items.

# Battery Activated Magnetic Lifter

- Battery only required to energise magnets
- Permanent magnets ensure failsafe operation
- 3:1 lift safety factor guaranteed
- Push button or automatic switch operation
- Optional remote control
- Built in safety mechanisms such as lifting eye sensor



## Re-chargeable batteries

- Lifter has built in socket for charging the battery on site

## Technical Data

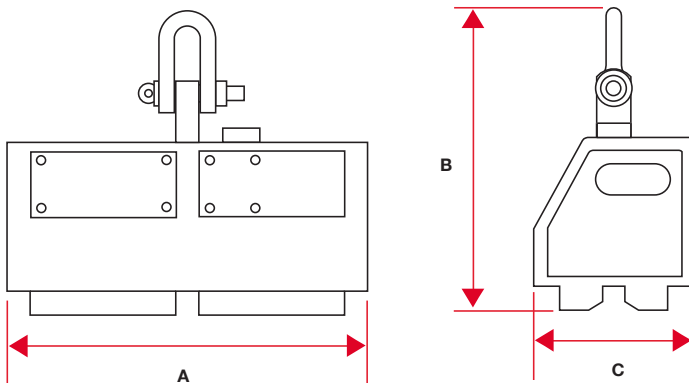

Product	Load profile	Unit Weight kg	SWL* kg	Diameter Min. mm	Diameter Max. mm	Dimensions mm		
						A	B	C
EPML1250R	Round	175	750	200	400	690	530	280
EPML3000	Flat	164	2400	N/A	N/A	690	530	280

\*Safe working load



# Optimag E

## Electronically switchable permanent magnets (ESPM)

- Ideal for clamping or lifting loads with clean, even, flat surfaces
- Suitable for applications which require sensing or built-in PLC control
- Failsafe operation - lose power it will retain the hold
- Ideal for materials from 10mm thick



### How it works

A single pulse of power switches the magnet by reversing the magnetic poles and in doing so changes the magnetic flux direction to hold or release the load. Magnetism is channelled to provide a deeper magnetic field making it ideal for thicker materials

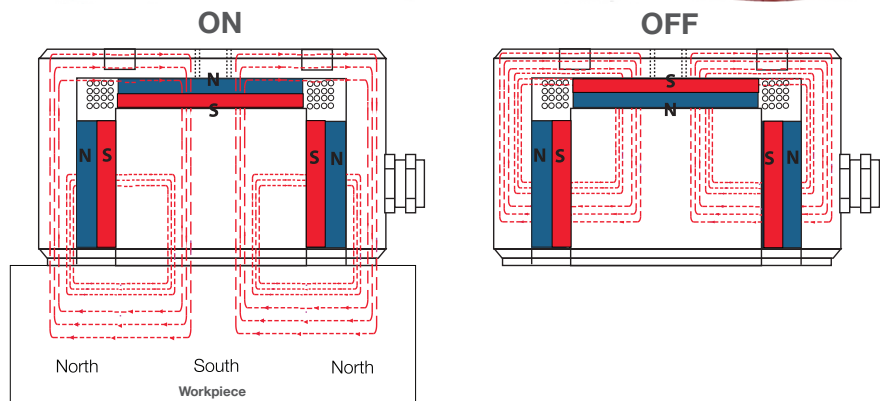

### Technical Data

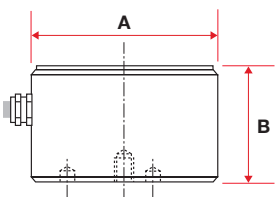

Circular Optimag E

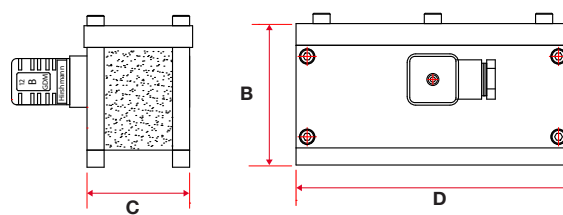

Rectangular Optimag E



ESPM Controller unit

Product	Load Profile	SWL* kg	Dimensions mm				Unit Weight kg	Rating
			A	B	C	D		
<b>Circular</b>								
ESPM80C	Flat	85	80	55	N/A	N/A	1.5	1.30
ESPM100C	Flat	150	105	55	N/A	N/A	3	1.90
ESPM125C	Flat	250	130	80	N/A	N/A	5.7	4.1
ESPM150C	Flat	400	155	80	N/A	N/A	8	5
<b>Rectangular**</b>								
ESPM284	Flat	42	N/A	83	40	80	1.4	1
ESPM286	Flat	49	N/A	83	60	80	1.9	2
ESPM2166	Flat	97	N/A	83	60	160	3.8	4
ESPM2246	Flat	146	N/A	83	60	240	5.9	6
ESPM2177H	Flat	300	N/A	130	75	170	11	12
ESPM2257H	Flat	450	N/A	130	75	250	16.5	18
ESPM2347H	Flat	600	N/A	130	75	340	22	24

Control Unit	Operating Voltage v	Rating	Dimensions mm		
			Width	Height	Depth
M24388/SC	240	50	300	300	155
M24388/DC	240	100	300	300	155
6001CONT	415	180	400	300	155
M24388/HAND	N/A	N/A	112	65	55
6001/MH	N/A	N/A	112	65	55

\*Safe working load

\*\*Can be manufactured to lift flat or round

# Optimag P

Pneumatically switchable permanent magnets (PSPM)

- Ideal for rigid, thin or perforated pressings or sheet
- Suitable for loads with rough, uneven or painted surfaces
- Failsafe operation - lose air clamping hold is retained
- Ideal for material thicknesses from 2mm thick

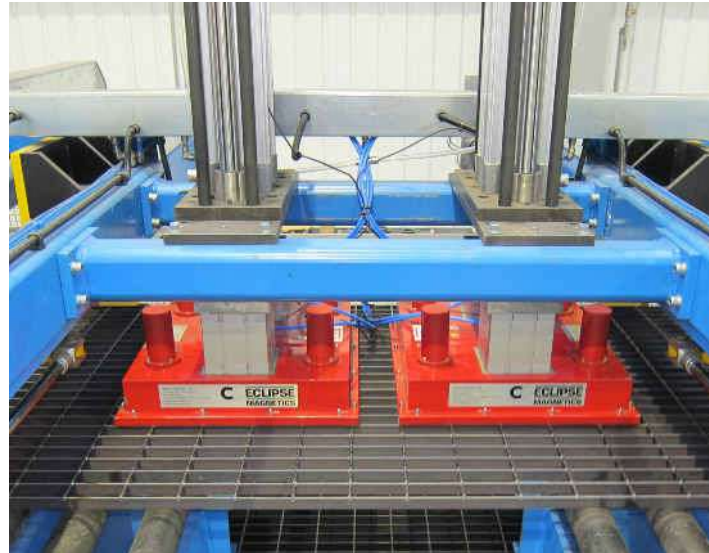
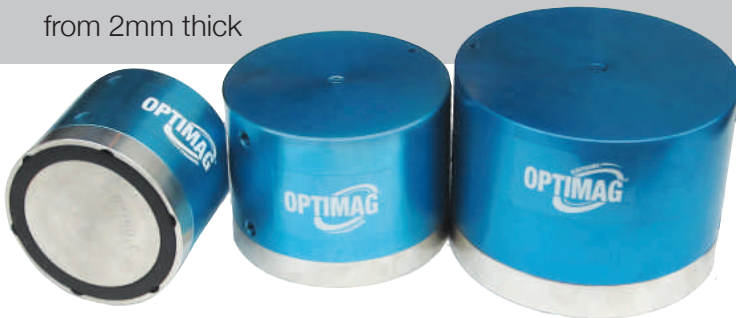

## How it works

A pulse of air moves the magnet pack up and down thereby directing the magnetic flux into or away from the load. The air is required only for switching, a constant air source is not required during clamping.

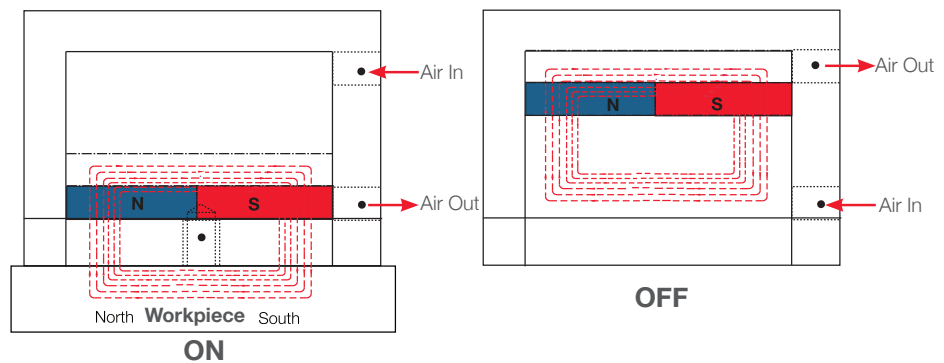

## Technical Data

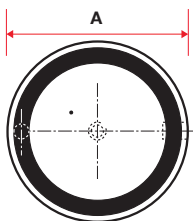

Circular Optimag P

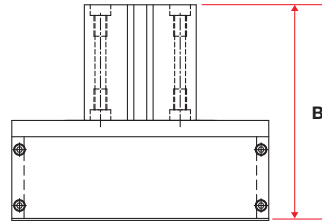
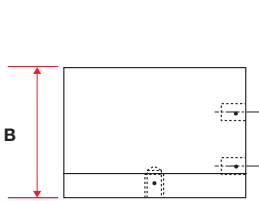

Rectangular Optimag P

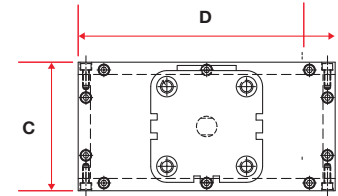

Product	Load Profile	SWL*	Dimensions mm				Unit Weight
			Diameter A	Height B	Width C	Length D	
		kg					kg
<b>Circular</b>							
PSPM80C	Flat	8.5	80	80	N/A	N/A	1.00
PSPM100C	Flat	18.5	100	84	N/A	N/A	1.50
PSPM125C	Flat	29	125	93	N/A	N/A	3.00
PSPM150C	Flat	59	150	109	N/A	N/A	4.80
<b>Rectangular</b>							
PSPM1520	Flat	35	N/A	165	200	150	6.00
PSPM2030	Flat	100	N/A	201	300	200	14.70

\*Safe working load

# Choosing the correct product (ESPM and PSPM)

The tables below are a guide to determine a typical safe working load and load dimensions for each Optimag E and Optimag P.

Recommended use shown in WHITE.

\*\*\*\*RED shows typical reduction in load due to thickness of material. **X** - Cannot be used for stated dimensions.\*\*\*\*

## Optimag E

Product	Load Profile	Max. SWL kg	Rating	Max. length (X)	Max width (Y) (At material thicknesses shown).	Material Thickness (T) mm							
						8	10	15	20	30	40	50	60

### Circular

ESPM80C	Flat	85	3.5	600	Max width (Y) (At material thicknesses shown).	X	600	600	600	600	457	366	300
ESPM100C	Flat	150	5	800		X	X	800	800	800	604	484	403
ESPM125C	Flat	250	9	1000		X	X	X	1000	1000	806	645	535
ESPM150C	Flat	400	12	1500		X	X	X	1500	1146	860	717	573

### Rectangular

ESPM284	Flat	42	6	400	Max width (Y) (At material thicknesses shown).	400	400	400	400	400	338	253	211
ESPM286	Flat	49	11	500		500	500	500	500	422	316	253	253
ESPM2166	Flat	97	10	800		800	800	800	782	521	391	312	260
ESPM2246	Flat	146	15	1000		1000	1000	1000	942	628	471	377	314
ESPM2177H	Flat	300	12	1200		1200	1200	1200	1200	1075	806	645	537
ESPM2257	Flat	450	18	1500		1500	1500	1500	1500	1290	968	774	645
ESPM2347H	Flat	600	24	1500		1500	1500	1500	1500	1500	1290	1032	860

## Optimag P

Product	Load Profile	Max. SWL kg	Max. Length (X) mm	Max width	Material Thickness (T) mm					
					3	5	8	10	15	20

### Circular

PSPM80C	Flat	8.5	400	Max width (Y) (At material thicknesses shown).	400	400	340	274	183	137
PSPM100C	Flat	18.8	500		500	500	500	484	363	242
PSPM125C	Flat	29	600		600	600	600	600	519	312
PSPM150C	Flat	59	800		800	800	800	800	638	475

### Rectangular

PSPM1520	Flat	TBA	N/A	Special Applications only. Please contact Eclipse Magnetics for details					
PSPM2030	Flat	TBA	N/A						

All details above are based upon the mild steel bright finish, if material is different please refer to material and air gap information page. The chart is to assist but once material thickness is identified maximum length can be shorter and width can be greater providing total area remains the same per magnet.

Once length / width (total area) exceeds the recommended dimensions for the thickness, additional magnets should be used. (See facing page). Number of magnets will continue to increase pro-rata to plate size. Always position magnets to suit thickest material. Contact our sales department for more information or for any specific requirements.

# Using multiple lifters

## Positioning the ESPM or PSPM lifter

Once the load dimensions exceed the maximum stated, multiple lifters must be used. Ideal positioning is shown below.

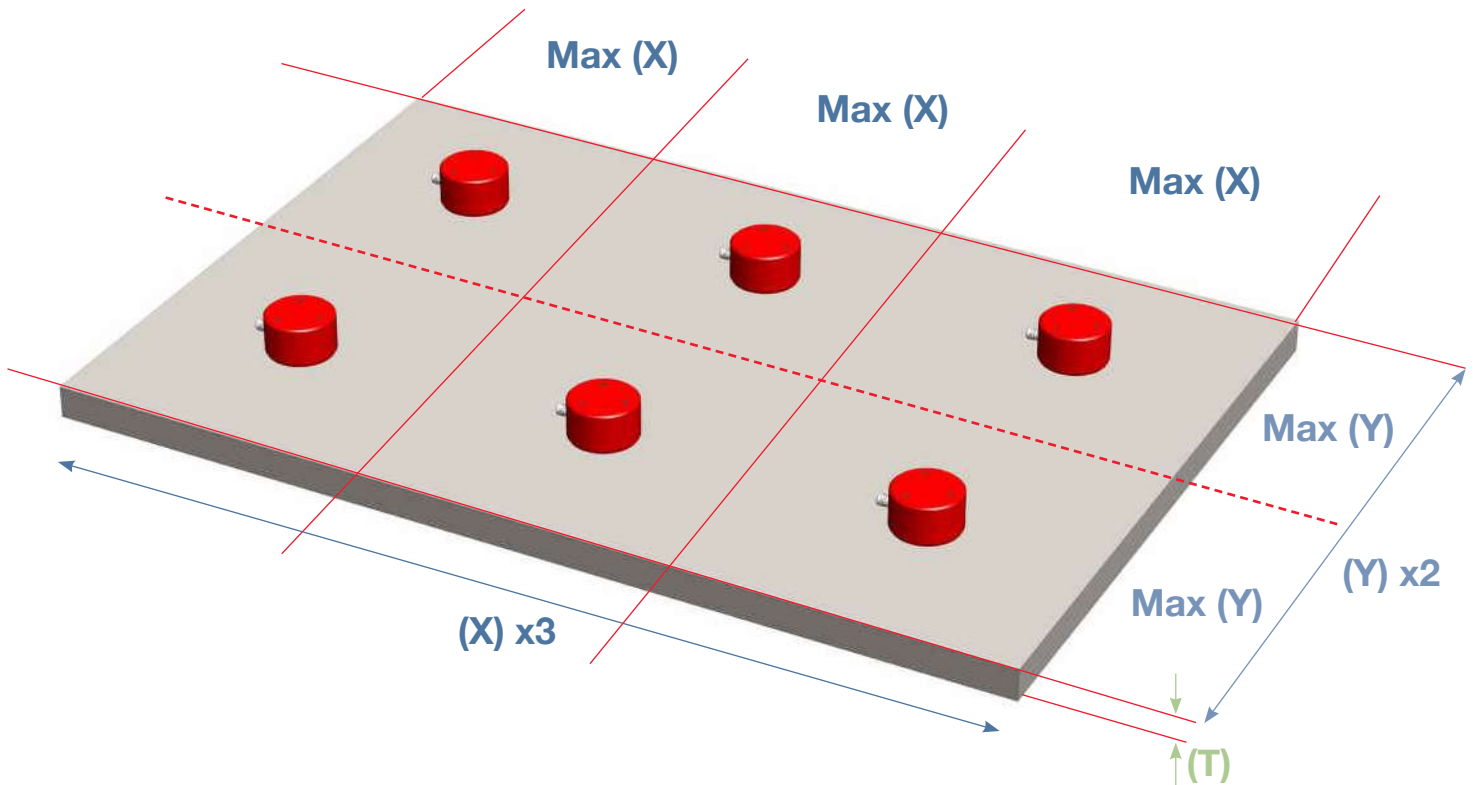

Optimag 166RR

Rectangular Optimag E is supplied for lifting flat and round material. These can be supplied with V pole extensions.



# Handling Accessories

## Sheet separators

- Safe, fast, efficient removal of single sheets of steel, or pressings from stacks.
- Prevents lifting of two sheets together.
- Range of options for most situations including switchable units designed for high speed / high volume production lines.
- Ideal for use with Eclipse Magnetics lifting magnets.

Easily separates the top item from a stack of sheet steel or pressed products from the rest of the stack ready for automated or manual removal.

Typically separates material from **0.2mm to 3mm thick** but almost any shape or size can be accommodated by products in our range. Separation ability can be reduced if oil or treated oil is present on the sheets.

### Technical Data

Product	Width mm	Height mm	Depth mm	Mounting hole size mm	Weight per pair kg
E913	73	76	65	M8	1.40
E914	92	102	76	M8	3.10
E915	113	152	89	M10	6.75

Product	Magnetic material	Mounting hole size	Height
		mm	mm
SF100/C	Ceramic	50	100
SF200/C	Ceramic	50	200
SF300/C	Ceramic	50	300
SF400/C	Ceramic	50	400
SF500/C	Ceramic	50	500
SF100/R	Rare Earth	50	100
SF200/R	Rare Earth	50	200
SF300/R	Rare Earth	50	300
SF400/R	Rare Earth	50	400
SF500/R	Rare Earth	50	500

All above ranges are 100mm wide, 50mm thick

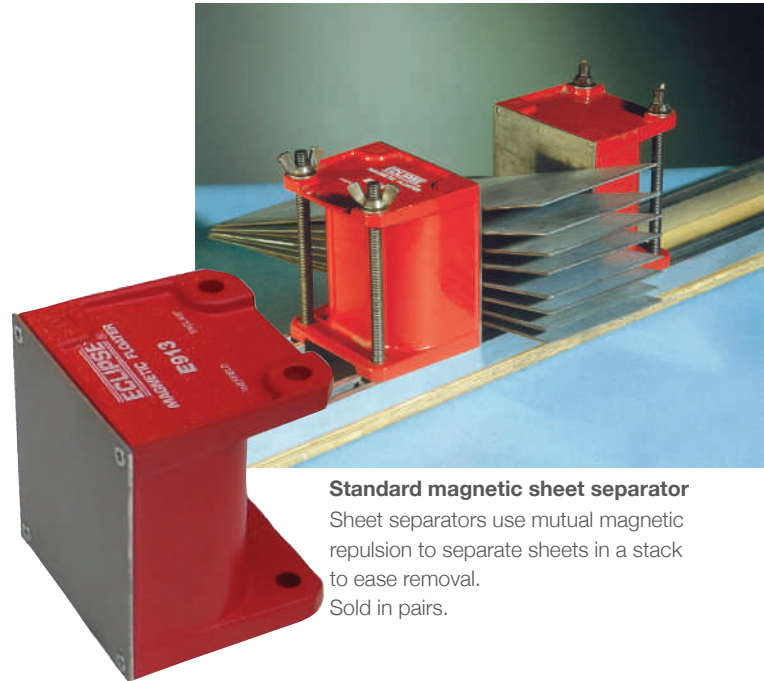

**Standard magnetic sheet separator**

Sheet separators use mutual magnetic repulsion to separate sheets in a stack to ease removal. Sold in pairs.

It's important to order the correct size of separator for the size of material to be separated. If the items are half the width of the separator the top items can flip onto the face of the separator instead of being separated.

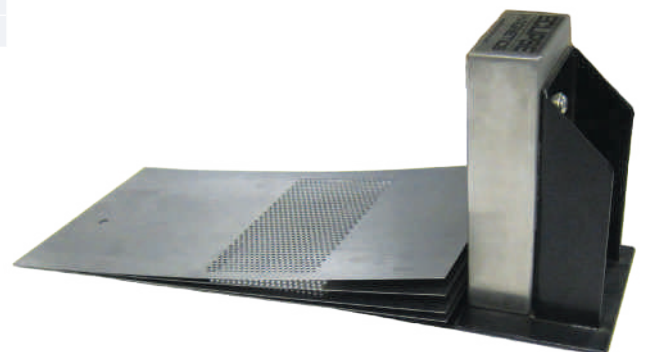

**Industrial (made to order) magnetic sheet separator**

# Service and maintenance

## Full inspection and certification

**All lifting systems should be serviced every 6 months by a competent person.** Our fully trained engineers provide a full inspection and certification service. (Please refer to local territory guidelines for inspection requirements).

### Periodic inspection

If the lifting magnet is being used in the EU then it must be inspected and maintained in accordance with the requirements of PUWER (1998) (UK Regulations).

For areas outside the EU the lifter must be inspected and maintained in compliance with the applicable standards for suspended load handling.

Should the data plates become detached or damaged please contact your supplier immediately for replacement plates.



## Other Products

In addition to our lifting and handling range, Eclipse Magnetics manufacture a wide range of high performance magnetic products for diverse applications.



Sub-micron filtration for industrial fluids



Workholding systems



Magnetic aids for workshop & general engineering applications



Magnetic materials & assemblies



Foreign body removal - separation & detection systems



Heating system filters

## Eclipse Magnetics Worldwide

### Europe

Atlas Way  
Sheffield  
S4 7QQ  
England

**T** +44 (0)114 225 0600  
**F** +44 (0)114 225 0610  
europe@eclipsemagnetics.com

### Americas

442 Millen Road, Unit 9,  
Stoney Creek  
Ontario, L8E 6H2,  
Canada

**T** +1 905-664-5585  
**F** +1 905-664-7090  
americas@eclipsemagnetics.com

### China

No. 168 Chengjian Road  
Minhang District  
Shanghai  
PR China

**T** +86 21 6434 8600 \*150  
**F** +86 21 6434 6488  
asia@eclipsemagnetics.com

Representative:

[www.eclipsemagnetics.com](http://www.eclipsemagnetics.com)

### Eclipse Magnetics Ltd

Atlas Way, Sheffield, S4 7QQ, England  
**T** +44 (0)114 225 0600 **F** +44 (0)114 225 0610  
info@eclipsemagnetics.com [www.eclipsemagnetics.com](http://www.eclipsemagnetics.com)

While every effort has been made to ensure the accuracy of the information in this publication please note that specifications may change without notice.



FM31278



v1